

Vehicle Electricity

DC Charging Systems

Test 1

Fan Drive Belt

The belt is checked for:

- i) correct tension
- ii) contamination by oil
- iii) wear (worn pulleys and belt wear/damage)

+ 11F 35 X

Tension: correct clean minimal wear "

General condition: clean minimal wear / "

Test 2

Terminal Connections

- i) clean
- ii) tight
- iii) correct

Condition: clean tight Bright / "

Test 3

Battery

The battery is tested to ascertain the state of charge:

- i) O.C.V. 11.5V /
- ii) S.G.

If the battery is discharged, (ie SG of 1.120) there should be an amperage reading of 5 amps + on an ammeter connected between the dynamo 'D' terminal and the battery. If charged, a reading of less than 5 amps should be obtained.

Battery condition: 11.5V X

Charge reading: 11.5V

DYNAMO TESTS

Test 4

Armature and Brushes

• MF 35

1. D and F Terminals disconnected at generator.
2. Voltmeter connected between D and earth.
3. The engine runs at 1500 rev/min (minimum) if the voltmeter reading is between 2 and 4 volts the armature and brushes are satisfactory.

Reading/Condition: ... 4 V ... Satisfactory ... 2 volts

Test 5

Generator Field Circuit

1. The Voltmeter is left as in Test 4.
2. An ammeter is connected between D and F terminals.
3. Run engine up until voltmeter reads 12 volts. The ammeter should then read 2 amps. (Field resistance 6 Ω).

Reading/Condition: ... 2 Amps ... circuit O.K. ... 12V 2A O.K.

Test 6

D and F Cable connections/continuity

1. Reconnect D and F of generator.
2. Disconnect D and F at Control box.
3. Repeat Tests 3 and 4 connecting meters to the ends of the leads.

Readings/Condition: ... 2 Amps ... 12 volts	12V 2A O.K.
... continuity ... leads ... parts of ...	continuity

CONTROL BOX TESTS

Test 7

Checking and adjusting Regulator Open Circuit Voltage

1. Reconnect D and F at Control box.
2. Remove 'A' and 'A1' and join them together.
3. Connect voltmeter between 'D' at control box and earth.
4. Run generator at 3000 rev/min the voltmeter reading should be between 15.8 and 16.5 volts.

Reading: ... 15 volts ... 16 volts

Note adjust to this specified value on the regulator adjusting screw if the test reading is found to be incorrect.

Test 8

M-F 35

Checking 'Cutting-in' Voltage

1. Connect ammeter in main 'D' lead between Regulator 'A' terminal and A and A1 cable where joined. Voltmeter between 'D' at control box and earth. (As previous test).
2. Run up engine with headlights on if fitted, voltmeter should 'kick-back' at between 12.75 and 13.3 volts. (When cut-out points close). Adjust if necessary (must be done with engine stopped).
3. Increase engine speed until ammeter shows a charge (in region of 5-10 amps).
4. Reduce engine speed slowly noting ammeter reading. Ammeter should register reverse current reading of 3-5 amps before suddenly zeroing (cut-out points open).

Readings: Cut-in: *13.3V* } *Battery or bulb fully charged & discharge was noted to be carried out.*
 Cut-out: *11V* } *2.8 amp*

Note adjust to correct specifications if necessary.

Test 9

Voltage drop

- a) Connect voltmeter across insulated supply circuit between 'D' terminal on dynamo and insulated supply battery terminal. Run engine up to charge speed (8-10 amps). Note voltmeter reading.
- b) Connect voltmeter across earth return circuit (between end plate on dynamo (brush box end) and earthed battery terminal). Run engine up to charge speed (8-10 amps). Note voltmeter reading.

Test readings Insulated supply: *0V* } *1.0V High resistance from cut out to earth*
 Earth return: *0V* } *0V OK*

NB: Max/voltage drop = 0.75 volt (0.5 V insulated supply 0.25 V earth return).

RB.108. CONTROL BOX. TRACTOR APPLICATION

OPEN CIRCUIT VOLTAGE SETTINGS

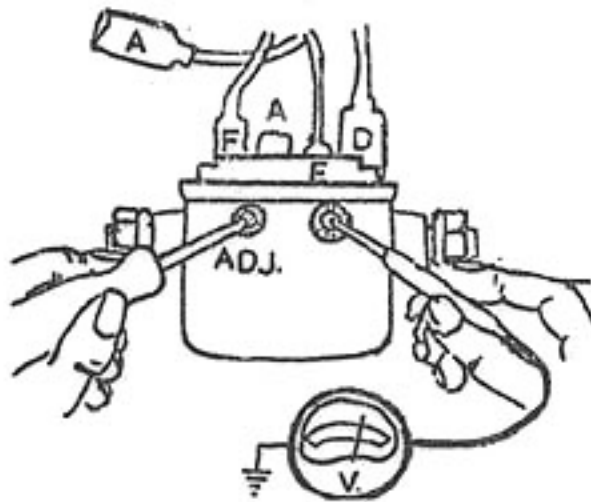

RUN ENG. AT 1800 R.P.M.

10°C.	16.1—16.7 V.
20°C.	16.0—16.6 V.
30°C.	15.9—16.5 V.
40°C.	15.9—16.4 V.

CUT OUT ADJUSTMENT

CUT IN VOLTAGE

(ENG. IDLE REDUCED)

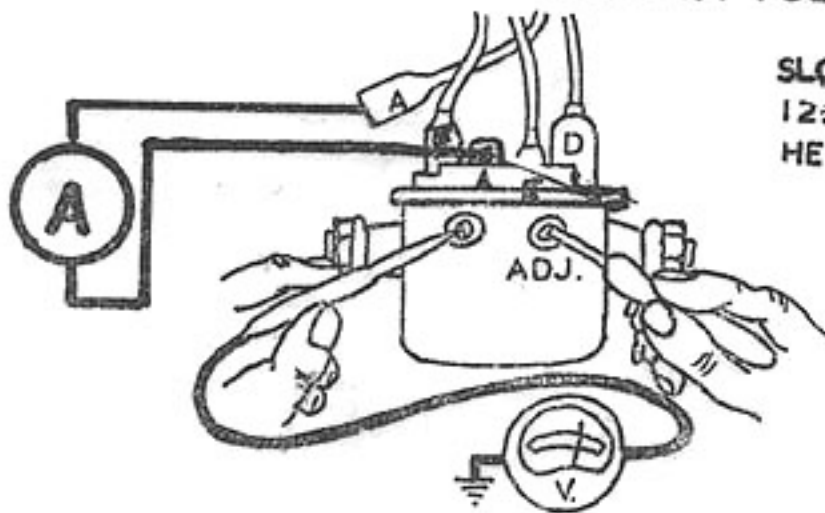

SLOWLY INCREASE DYNAMO SPEED.
12.7—13.3V BEFORE NEEDLE
HESITATES & POINTS CLOSE

DROP OUT CURRENT

FROM A CHARGING CONDITION
DECELERATE ENGINE.
REVERSED FLOW TO BE 3-5 AMPS

(BEND FIXED CUTOUT POINT)

RB 340 REGULATOR TRACTOR APPLICATION VOLTAGE REGULATOR ADJUSTMENT

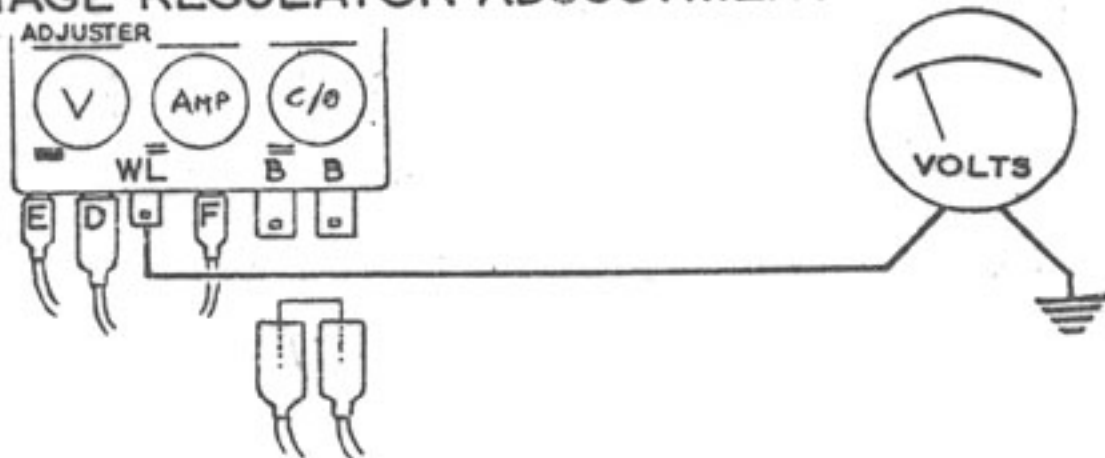

MAX. LOAD (LIGHTS ETC., ON)

CUT OUT ADJUSTMENT

CUT IN VOLTAGE (ENG. IDLE REDUCED) SLOWLY INCREASE DYNAMO SPEED
12.6—13.4V BEFORE NEEDLE DR

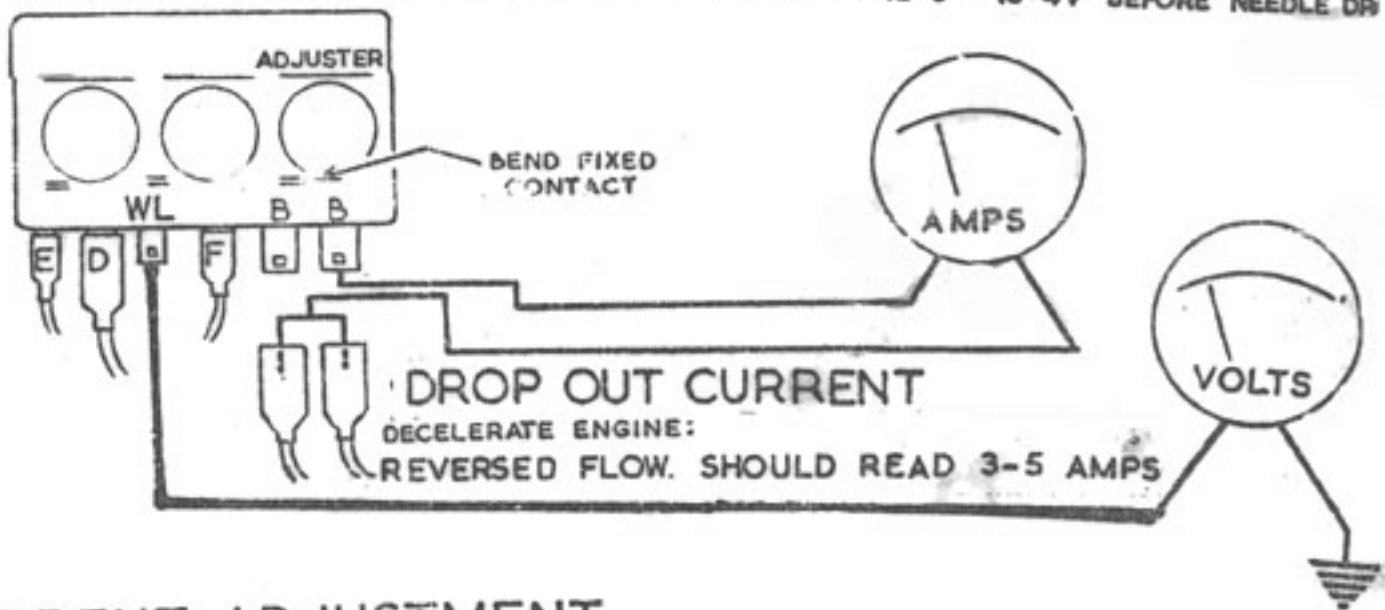

CURRENT ADJUSTMENT

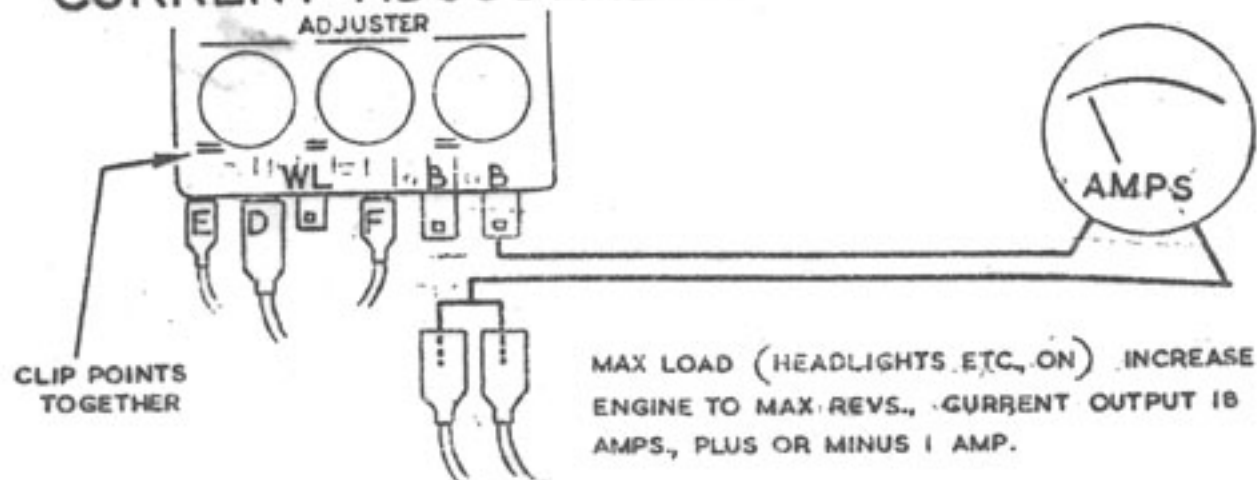

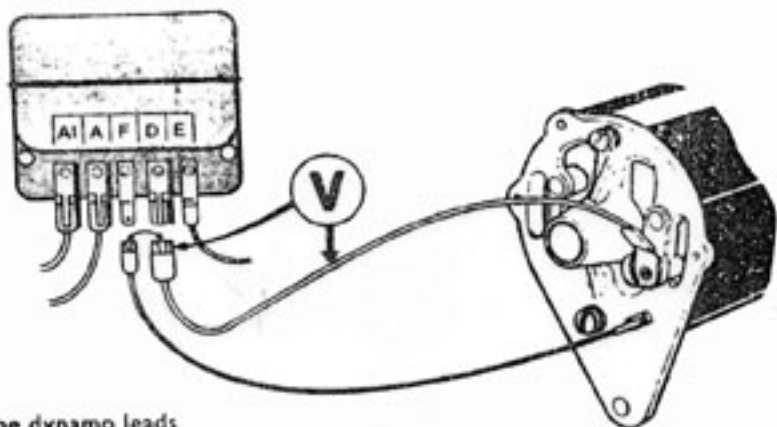

Checking the dynamo leads

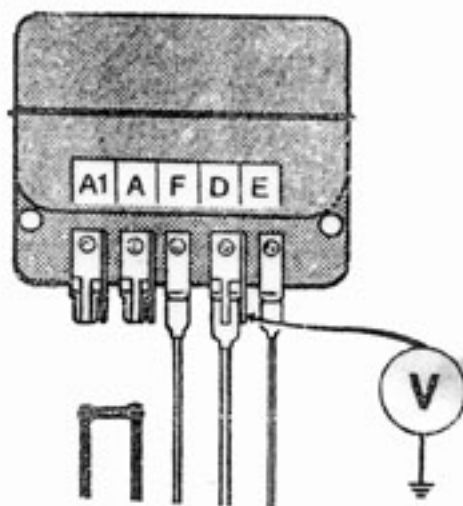

OPEN CIRCUIT VOLTAGE SETTING

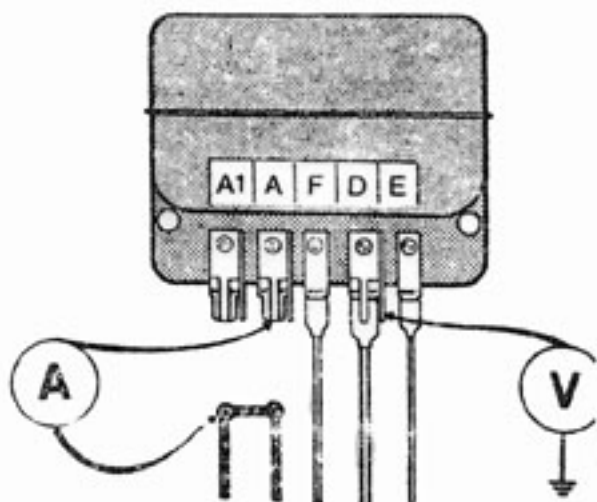

CUTTING IN VOLTAGE

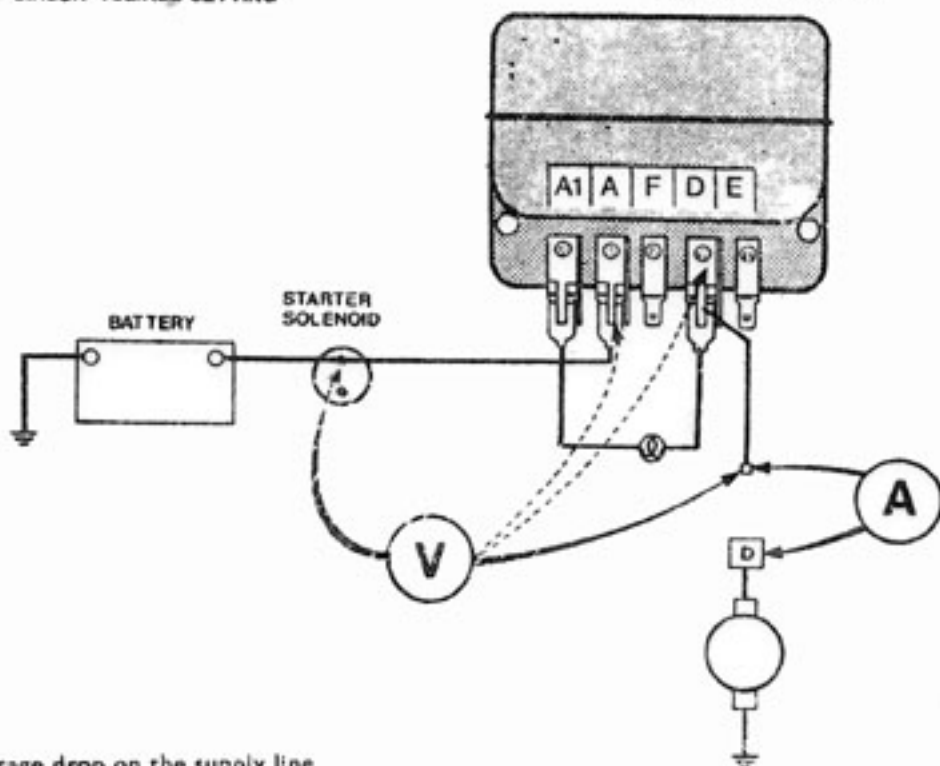

Voltage drop on the supply line

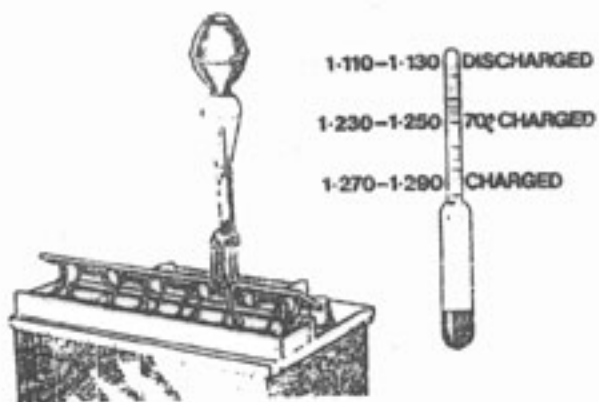
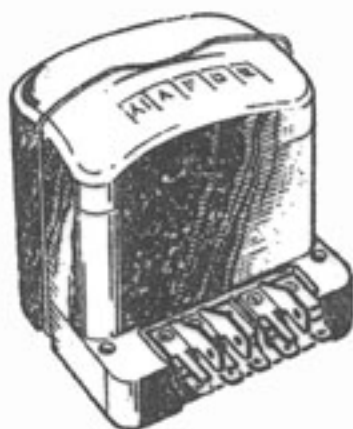
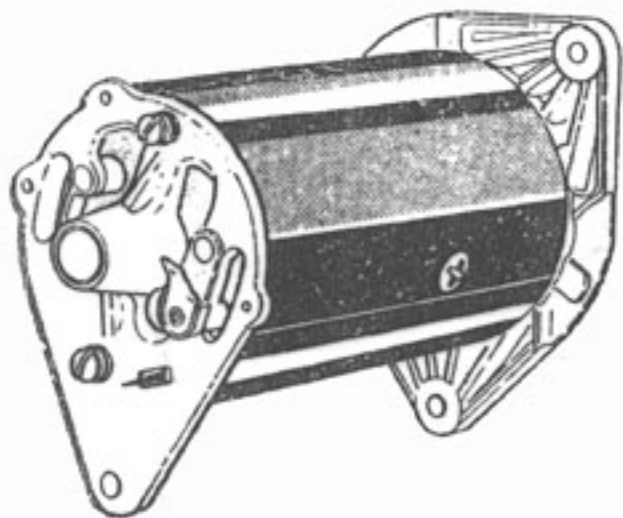

Hydrometer test

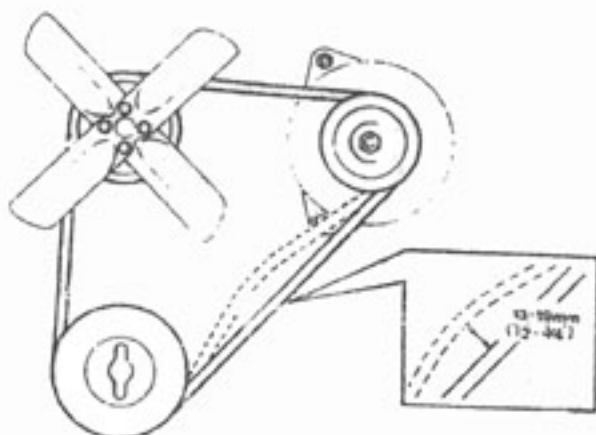

Drive belt tension

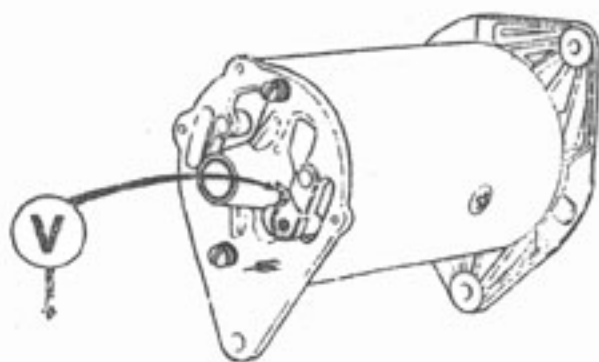

Testing the armature circuit

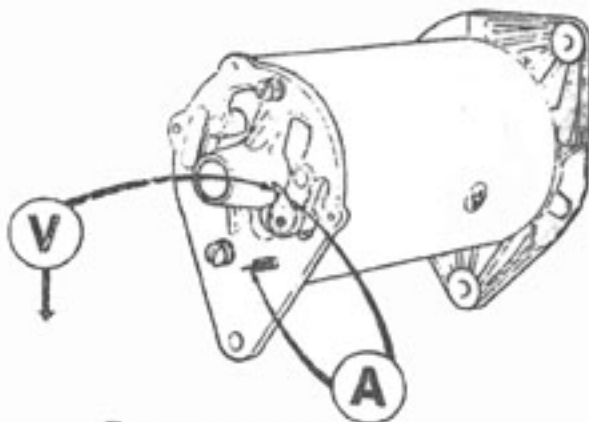

Testing the field circuit